

# LOW COST, ASIC BASED TELEMETRY AND TELECOMMAND SYSTEMS - THE TEAMSAT EXPERIENCE

C.B. Smith, M. Bandecchi, S. Habinc, D. Hardy, P. Sinander

*Directorate of Technical and Operational Support  
European Space Agency, PO. Box 299, NL-2200 AG, The Netherlands  
phone: +31-71-565 6565, fax: +31-71-565 4295, email: csmith@estec.esa.nl*

## ABSTRACT

*The TEAMSAT dual spacecraft launched by the Ariane 502 test launch was completed in record time (7.5 months from go-ahead to delivery) and very low cost. The data handling system was ready to support final integration and testing in 6 months despite the fact it had to be designed and constructed from scratch. A vital element in this achievement was the availability of ESAs Telemetry (TM) and Telecommand (TC) chip set. This paper briefly outlines the spacecraft and its mission but with particular reference to the data handling system and the severe constraints under which it was developed.*

## 1 INTRODUCTION

In mid November 1996, 750 000 Euro was provided to enable young engineers and students to exploit the opportunity offered by the Ariane 502 test launch to install some experiments aboard the MAQSAT instrumented test platform which would go into Geostationary Transfer Orbit (GTO). Space was available for a cylindrical module about 94cm high and 75cm diameter weighing up to 300 kg. Thanks to the enthusiasm of the team and the mostly free ESTEC in-house support, facilities and expertise, the TEAM/YES dual spacecraft (TEAMSAT) was ready for shipment to Kourou by the end of June 1997. However, the data handling system and ground support equipment had to be ready about 6 weeks earlier to support integration and testing via the TM and TC links. The A-502 authorities subsequently delayed the launch until 30th October. This paper principally concerns the On Board Data Handling (OBDH) system, but we have added information about the spacecraft and mission in general to give some idea of the scale of the challenge this project presented.

## 2 EXPERIMENTS AND SUBSYSTEMS REQUIRING TM/TC SUPPORT

Candidate experiments had to be in an advanced stage of development and suitable for the GTO provided by the launch. As far as the OBDH is concerned, the following experiments and subsystems established the initial requirements it had to meet.

**TETHER** This involved the in-flight deployment of a daughter spacecraft (Young Engineers Satellite - YES) that was to be ejected as a free flyer attached by a 35 km tether to a 12 kg counter mass. The YES satellite and its support systems plus the details of the tether deployment were still being discussed.

**AVS** Autonomous Vision System. Provided an astronomical attitude reference by recognising star constellations. An existing development model was

available including a PC based ground support system.

**FIPEX** Flux Probe Experiment. Measured atomic oxygen. Examples already flown on sounding rockets. Included PC based ground support system.

**VTS** Visual Telemetry System. Existing engineering model of a programmable digital camera system for monitoring spacecraft mechanical status, array deployment, separation etc. PC based ground support system existed.

**GPS** A commercial GPS receiver was included to obtain position data and study reception conditions above the GPS satellite constellation. PC type serial output.

**Platform** Analogue and digital housekeeping channels were required to monitor relay states, voltages, temperatures, currents etc.

All the above required telecommand facilities to load memories, execute control commands etc.

## 3 CONSTRAINTS AND WAYS ROUND THEM

TEAMSAT had to behave as an inert dummy load in MAQSAT until after final separation. It also had to be very robustly constructed or contained so that there was no danger of bits falling off during the launch. Electrically, it meant no RF transmissions and no live connections outside the TEAMSAT box until after MAQSAT separation.

There was no possibility to mount solar arrays, so a short lifetime, battery powered mission was the only possibility. Spare batteries from ECS II (1982!) were found to be still serviceable and provided about 3 kWh of capacity. With careful conservation and short hibernation periods, we guesstimated that a mission spanning about 4 days should be possible.

The extreme time and budget constraints obliged us to resort to some unusual and frankly dubious practises on occasions. Normal QA procedures could not be applied and such decisions were left to the judgement of the person on the spot, aided by the vast pool of expertise available in ESTEC. The imposed deadlines often forced us to start construction based on provisional assumptions before some important parameters were frozen or even identified. In effect phase A/B lasted only a week or two and merged rather than switched into phase C/D. This meant we required designs with reconfigurable capabilities that could be adjusted later rather than inflexible, case specific solutions.

When integration and testing of TEAMSAT was already well advanced, a decision of the Space Debris Committee led to the abandonment of the major experiment, TETHER. By that time

YES and its deployment system had been fully developed and installed. It was decided that YES would be ejected, but the deployment of the tether and the counter-mass would be excluded.

#### **4 MECHANICAL DESIGN AND YES DEPLOYMENT SYSTEM**

The main mechanical features of TEAM and YES can be seen here, including the intended deployment of YES. Both spacecraft are in a robust octagonal box which ensures containment of everything inside. The YES spacecraft uses the octagonal lid of the TEAMSAT box as a base-plate for its structure and is ejected by four springs on reception of a ground command to a pyrotechnic release system. Then the 35 km tether unwinds from a bobbin in YES while the counter mass remains in TEAM. After full tether deployment, the counter mass is released from TEAM. The TEAM spacecraft remains attached to MAQSAT throughout the mission. Deployment control placed severe requirements on the TM and TC to ensure that it took place reliably at exactly the right time and spacecraft orientation. Finally, to preserve the mandatory mechanical integrity during launch, the YES release system had to meet the strictest safety requirements.

#### **5 DATA HANDLING SYSTEM DESIGN DECISIONS AND TRADEOFFS**

We had acquired transponders left over from the Eureka and Olympus projects. They both functioned well when tested although the Olympus transponder used on YES was an engineering model at least 16 years old. (It actually failed towards the end of the mission, but by that time the effect was minor.) The most serious omission from the list of essential, available equipment was an on board data handling system to format the experiment data for transmission and decode and distribute commands and data received from the ground. Also still to be addressed were the issues of providing platform housekeeping data, plus power distribution, switching and conditioning.

In general, the experiments were off the shelf and came with existing display and control systems. To be able to use these during integration and test and also in flight required a suitably transparent space link. This in turn meant that there was no possibility of imposing on users the decidedly non transparent, traditional ESA TM system that collects fixed quantities of data at fixed intervals. The requirement to accept user data structures and I/O protocols as is meant we had to provide them with an asynchronous byte stream service rather than a packet service in both up and down links.

However, the ESA TM/TC chipset supports all these capabilities and is fully compliant with ESA/CCSDS recommendations. Its use dramatically reduced the effort of designing a data handling system from scratch. This chipset forms the core of an on board system that generates TM transfer frames and decodes TC frames without the involvement of a processor. Its flexibility enables details of TM bandwidth allocation amongst users to be left until later and even adjusted in flight.

It was clear that the link budget around apogee would be marginal. Fortunately, the ESA chipset includes a Reed-Solomon and Convolutional Encoder that provides about 7 dB of gain on the link. Even then, concerns about antenna pattern holes and their effect on the critical YES deployment sequence led us to provide cross coupling between the two spacecraft that enabled essential TM and TC traffic of one to be routed via the RF link of the other. To gain yet more link margin, provision was made to reduce TM bit rates by factors of 2 or 4 by telecommand. TEAM was provided with two low gain helical antennas mounted on the MAQSAT structure to provide reasonably uniform coverage in the aft direction in which (it was hoped!) the earth would lie at apogee. YES had 2 low gain antennas, positioned to provide the best omnidirectional capability in free flight, i.e. on opposite ends of the spacecraft. One of these was mounted on the exposed lid which meant that before deployment, the other was inside the composite TEAM/YES box and so had to be switched off to avoid RF interference. All together, the uncertainties of the RF links imposed some sophisticated requirements on the data handling system.

All the power switching relays, voltage converters, housekeeping and signal filtering functions were included in the same box as the data handling system. This created a self-contained service module (the OBDH Box) to which the experiments could be connected using their existing, PC type serial interfaces. The boxes for both spacecraft were mechanically identical. Each contained a TM board and a TC board customised to the requirements of the host spacecraft.

#### **6 THE ESA TM/TC CHIP SET**

All components use latch up free, rad-hard SOS technology, have a footprint of about 8cm<sup>2</sup> and weigh about 15 grams. Their functionality is fully compliant with ESA/CCSDS recommendations.

##### Telemetry

##### *Virtual Channel Assembler (VCA)*

Assembles packets or bytes of data into a VC on the TM link (one VCA per VC). Applies flow- control (optionally) to match the data source production rate to the bandwidth available to that VC. Accepts data as ESA/CCSDS packets or byte stream. TEAM used 5 VCAs and YES used 4.

##### *Virtual Channel Multiplexer (VCM)*

Multiplexes outputs of up to 8 VCAs on to one TM link. An in flight programmable Bandwidth Allocation Table guarantees minimum portions to each VC. The VCM completes the transfer frame header (spacecraft ID etc.). Also provides interfaces for the Command Link Control Word (CLCW) from the TC decoder chip and the Reed-Solomon / Convolutional encoder chip. Each spacecraft used one VCM.

##### *Reed-Solomon / Convolutional Encoder*

Supports the on board end of a forward error detection and correction system. Provides a very cost effective means of improving link budgets by about 7 dB. A complete, ESA/

CCSDS compliant TM frame generator comprises a single VCM plus a VCA for each VC used (maximum 8). The R-S/Conv. encoder chip is optional, but was essential to meet minimum link budget requirements in the case of TEAMSAT.

#### Telecommand

##### *Packet Telecommand Decoder*

The protocol machine supporting the on board end of an up link providing error-free delivery of packets or arbitrary data structures via up to 62 addressable ports. Also hosts an Authentication check (not used for TEAMSAT) and a Command Pulse Distribution Unit (CPDU) which decodes multiple pulse commands (direct TC) of individually specified length delivered in a packet.

The TC decoder chip is a device that eliminates the requirement to implement and check compliance with the fairly complex ESA/CCSDS TC protocols. Mission dependent parameters are held in a PROM. The transponders did not demodulate the PSK subcarrier. This was performed on the TC board by a single chip device of which we had a few samples

## **7 USE OF FIELD PROGRAMMABLE GATE ARRAYS (FPGA) AND VHDL TOOLS**

Most of the glue logic required to convert the ESA TM/TC chip set input and output ports to the PC type serial ports of users was implemented in ACTEL 1280 FPGAs. There was one on each TM and TC board. The TM FPGA also supported the digital part of the housekeeping system including the controller for the analogue section. The TC FPGA also supported the delay generator for time tagged commands. The design process produced VHDL models of the FPGAs. Since we had an already existing VHDL library of the ESA chip set and some other key components including the ground segment, this enabled us to model and verify the data handling system end to end in considerable detail at an early stage. This was an important factor in achieving a successful circuit board design very quickly and at the first attempt. Socket mounting was used for the FPGAs so that circuit adjustments could have been incorporated later. However the design process and simulation was so successful, corrections were not required.

## **8 SELF-ADAPTING, ASYNCHRONOUS TM SERVICE**

This capability requires particular mention since by using the old, synchronous, fixed format approach useful data retrieval would have been severely restricted and the design of user interfaces made much more complex. The simplified format tables below compare the two approaches.

In this example, the data points are scanned in a fixed sequence repeated every three frames (each line is a frame). Thus, data values are repeated whether they are useful or not, e.g. constant values and zeroes when the data source instrument is switched off. In effect, instruments are forced to produce data to maintain the fixed format of the transfer frame.

Although the VCM/VCA chip set frame also has a fixed size, its internal format adapts itself dynamically and the VC reporting sequence, packet rate and size vary according to user activity (event driven TM). Filler is inserted automatically to complete the fixed transfer frame format when user outputs are insufficient. This enables the system to accept user data as random squirts of various sizes. The bandwidth available on the TM link was 28 259 bits/s (overheads removed). The system shared this among users so that each got a guaranteed share, but any not taken up by one user would be offered to other users in proportion to their guaranteed share. The guaranteed shares to each VC are established by a VCA polling table hosted by the VCM. This can be reloaded in flight via the TC link. If users failed to accept all the bandwidth offered, the generator completed frames with filler.

The AVS experiment on TEAM is a good example of a sporadic data producer with no flow control. This meant its VC had to be guaranteed sufficient bandwidth to accept peak rate production. In quiescent mode it produced a small squirt of housekeeping data from time to time, but when an image was taken a more prolonged squirt would be produced. The experiment had no output flow control so the TM system had to accept the data as it was produced at 19.2 kBaud from its PC type asynchronous serial interface. Although the VC bandwidth provided matched this peak requirement, it was only taken up occasionally. The FIPEX experiment also on board TEAM was somewhat similar in its data production characteristics.

The VTS unit on TEAM produced small amounts of housekeeping as a background activity but it also had a very large image buffer. Its output interface was flow controlled. It complemented AVS and FIPEX since it could soak up the substantial bandwidths allocated to them but not used most of the time. In effect, the VTS buffer was emptied as fast as the total link bandwidth and current activities of the other users would allow.

Multiple users may share a common channel by using standard packet structures to delimit the different data units. Since we could not impose such structures on users, delimiting was done by allocating them different Virtual Channels (VCs) and Multiplexer Access Points (MAPs) on the TM and TC links respectively. This is not necessarily a strategy we would advocate in other circumstances since VCs and MAPs are intended primarily to delimit different levels of service and/or address redundant paths in the transport layer. Then a given VC or MAP may carry packets with compatible requirements for bandwidth and latency but with different sources and destinations, as identified by the packet Application IDs. Only the housekeeping subsystem, being an in house design, used the packet mode. The ESA TM chip set was designed to support simultaneous bytestream and packet modes on different VCs or MAPs.

## **9 DATA HANDLING SYSTEM PERFORMANCE AND CONCLUSIONS**

TEAMSAT is the first ESA spacecraft to be flown with TM and TC systems both fully compatible with ESA/CCSDS standards and the first spacecraft anywhere to exploit the adaptive, asynchronous TM capabilities they support. The performance

and ease of use delighted everybody. Much data was produced of scientific and also technical interest for future applications of the instruments flown. (See appendix). The short, relatively trouble free design and construction phases owed much to the use of the ESA TM/TC chip set which implemented all the core functions and protocols. The availability of these well proven protocol machines provided a major shortcut by avoiding the use of a processor and software, thereby providing a more robust system and eliminating the protocol verification tests which otherwise would have been required.

The efficient, adaptive behaviour of the TM system in accepting asynchronous, event driven inputs is of particular note. It is a mode of operation that, considering it too complex, project groups and industry have so far mostly avoided. In successfully flying such a system straight off the drawing board after ultra-short design and construction phases, we have demonstrated that when using the ESA chip set, such misgivings are unfounded. Indeed, this mode is much easier to use than the traditional fixed format approach, not only for data handling system designers, but also for instrument designers who are provided with a much less rigid interface and data presentation environment. The system is inherently able to handle variable size, variable rate data units ESA/CCSDS packets or otherwise. This means that on board data compression, event driven TM production and user defined, variable data sampling strategies can all be handled by the TM link without any special provisions other than a suitable minimum VC bandwidth allocation. The VC Bandwidth Allocation Table (BAT) can be reloaded in flight.

There was no mission requirement for the authentication process supported on the TC chip so it was not used. The only other ESA/CCSDS capability not demonstrated in flight was the COP-1 TC link protocol (for automated in-sequence error free delivery). TEAMSAT was the first ESA spacecraft to support it and there had been no time to verify ground station compatibility. However, its functionality on board had already been verified during integration and testing and the effectiveness of COP-1 in flight had already been demonstrated convincingly in 1994 by the low cost STRV-1 A and B satellites built by DERA, UK.

The TEAMSAT project has proved that a spacecraft data handling system of high performance and guaranteed compliance with ESA/CCSDS standards can be designed and built quickly and cheaply by using commercially available, space quality TM/TC components. These are mutually compatible, come with all the tricky protocol machines embedded in their silicon and so enable the radically new system capabilities and standards they support to be implemented with no risk. They are outputs of an on going TOS-ES development activity exploiting VLSI technology to reduce costs and improve performance in the framework of the new ESA/CCSDS standards. About 10 ESA projects are already committed to using them plus several national and commercial projects.

## 10 OVERVIEW OF MAIN EXPERIMENT RESULTS

### VTS

This is an image from a sequence taken during final separation. It gave valuable information for the evaluation of the A502 launch. What appear to be loose filaments are visible at about 4 o'clock. This was unexpected and is being investigated.

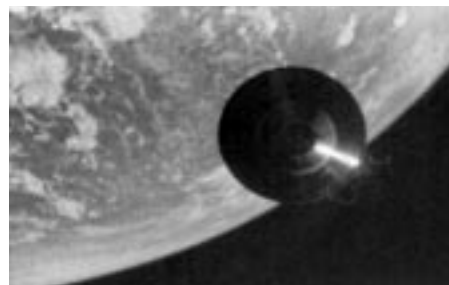

### AVS

Stellar objects can be differentiated from other objects and radiation effects in AVS images. The orientation of the host spacecraft is established from the measured star vectors. TEAMSAT provided the first in orbit demonstration of this new instrument. AVS will be part of the navigation system of Pluto Express that JPL plan to launch in 2001.

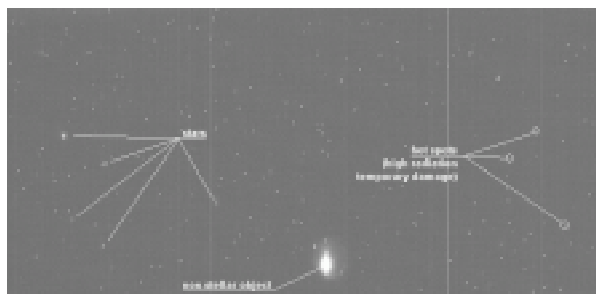

### FIPEX

During perigee passes, FIPEX measured the levels of atomic oxygen at altitudes between about 525 km and 1 250 km. A calibration measurement was made at apogee (about 26 000 km.). Atomic oxygen degrades optical surfaces and various materials, so this information will be a valuable input for the design of future spacecraft intended to orbit at such altitudes.

### GPS

GPS signals were received up to 26 000 km, 6 000 km above the GPS satellite constellation thus indicating that the system is still usable at such altitudes. This is believed to be a world first.

## 11 REFERENCES

TEAMSAT site <http://www.estec.esa.nl/teamsat>

ESA Microelectronics site <http://www.estec.esa.nl/wsmwww>

## Comparison Between Synchronous and Asynchronous Data Reporting in the TM Transfer Frame

Fixed Sequence Data Point Sampling

Header	A	B	C	D	A	E	F	G
	A	B	C	D	A	H	I	J
	A	B	C	D	A	K	L	M
	A	B	C	D	A	E	F	G
	A	B	C	D	A	H	I	J
	A	B	C	D	A	K	L	M

Data values are reported in fixed positions in the transfer frame whether they contain useful information or not.

Asynchronous Packet and Byte Stream Service

Header	VC1	Byte Stream A						
	VC2	Pkt 1	Pkt 2	Pkt1	Pkt 3	PKT4	→	
	VC3	Byte Stream B						
	VC2	→ Pkt 4 (continued)	Pkt 5	Pkt 6	Pkt 2	→		
	VC3	Byte Stream B						
	VC2	→ Pkt 2 (cont.)	Pkt 7	Pkt 1	Filler (no data avail.)			

VC reporting sequence and packet rate and size varies according to user activity. Filler is inserted to complete frames or create dummy frames when users are unable to fill the bandwidth offered.

### TEAM Telemetry Board

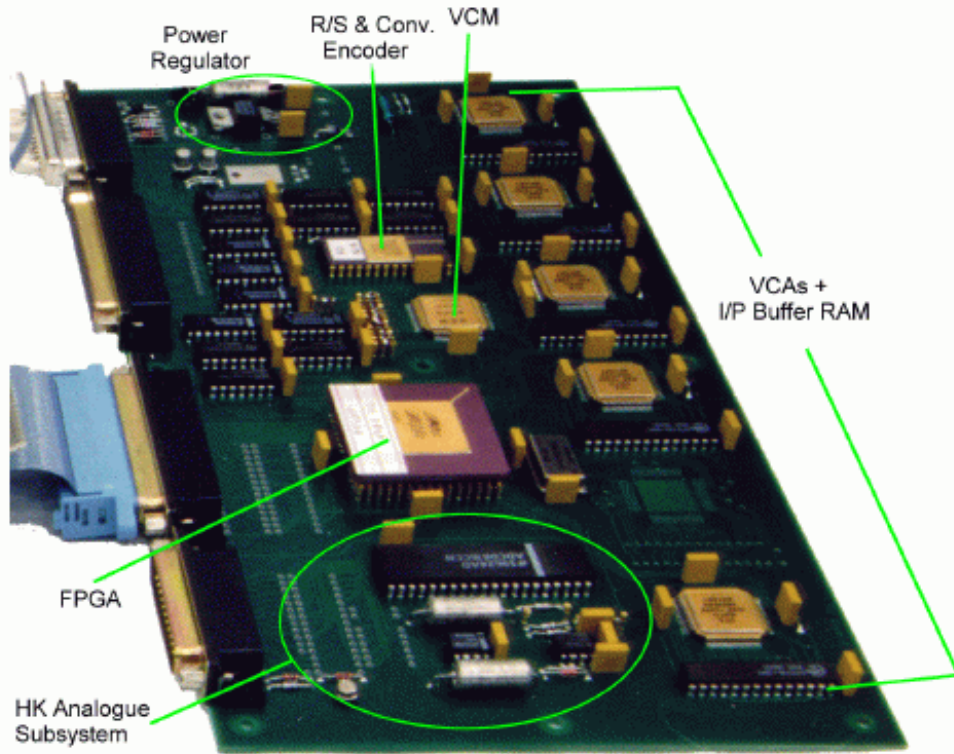

### TEAM Telecommand Board

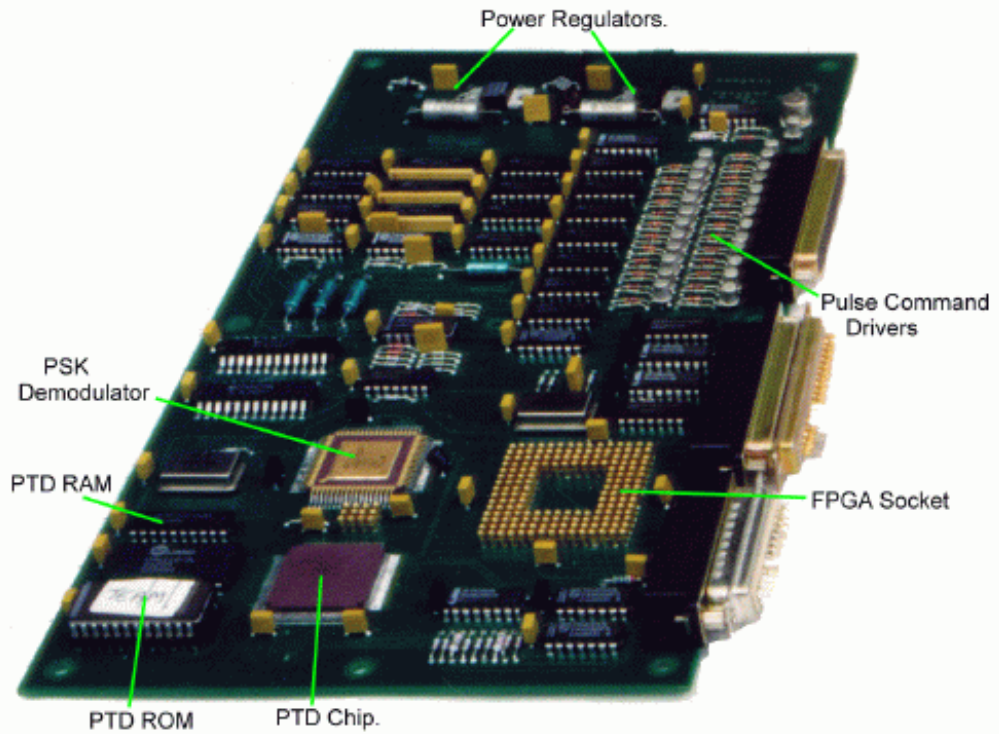

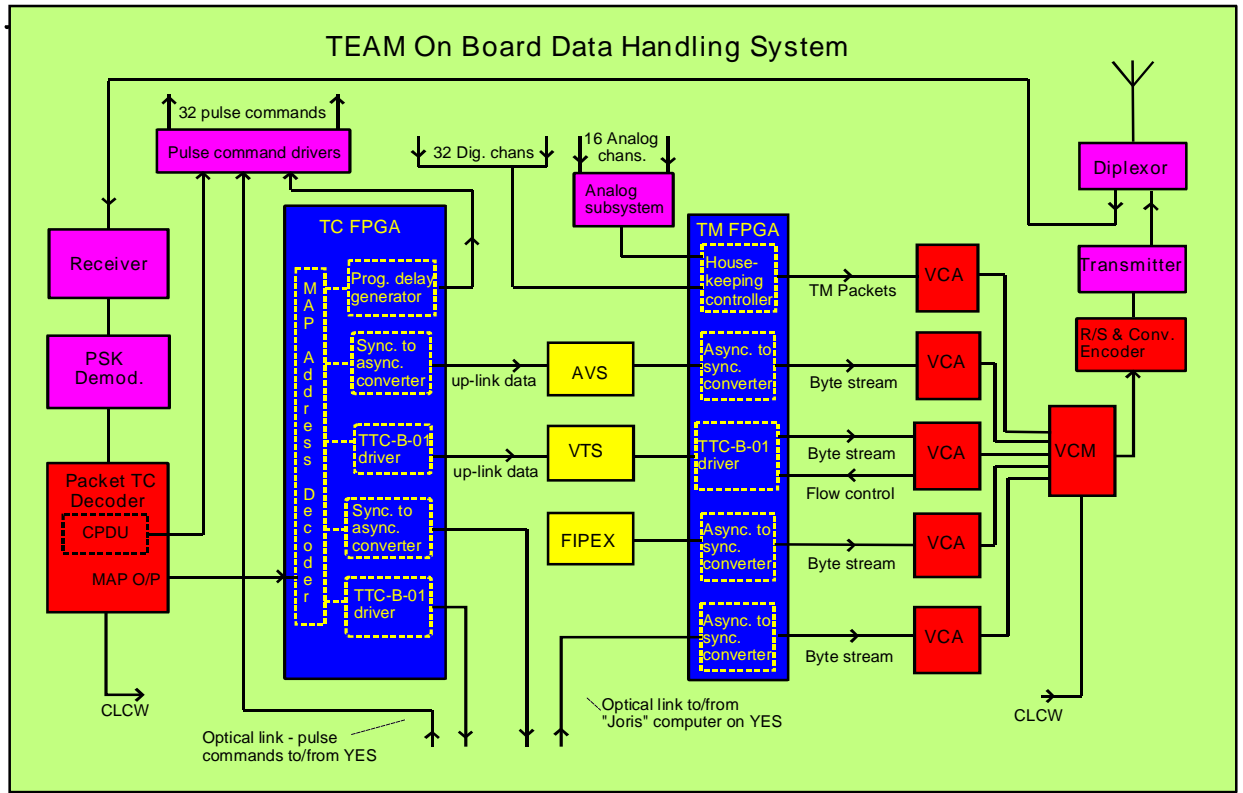



# TEAM Structure.

